

Overview of cost setting process on formation and entry (including transitional rules)

Figure 1: Cost setting process on formation and entry

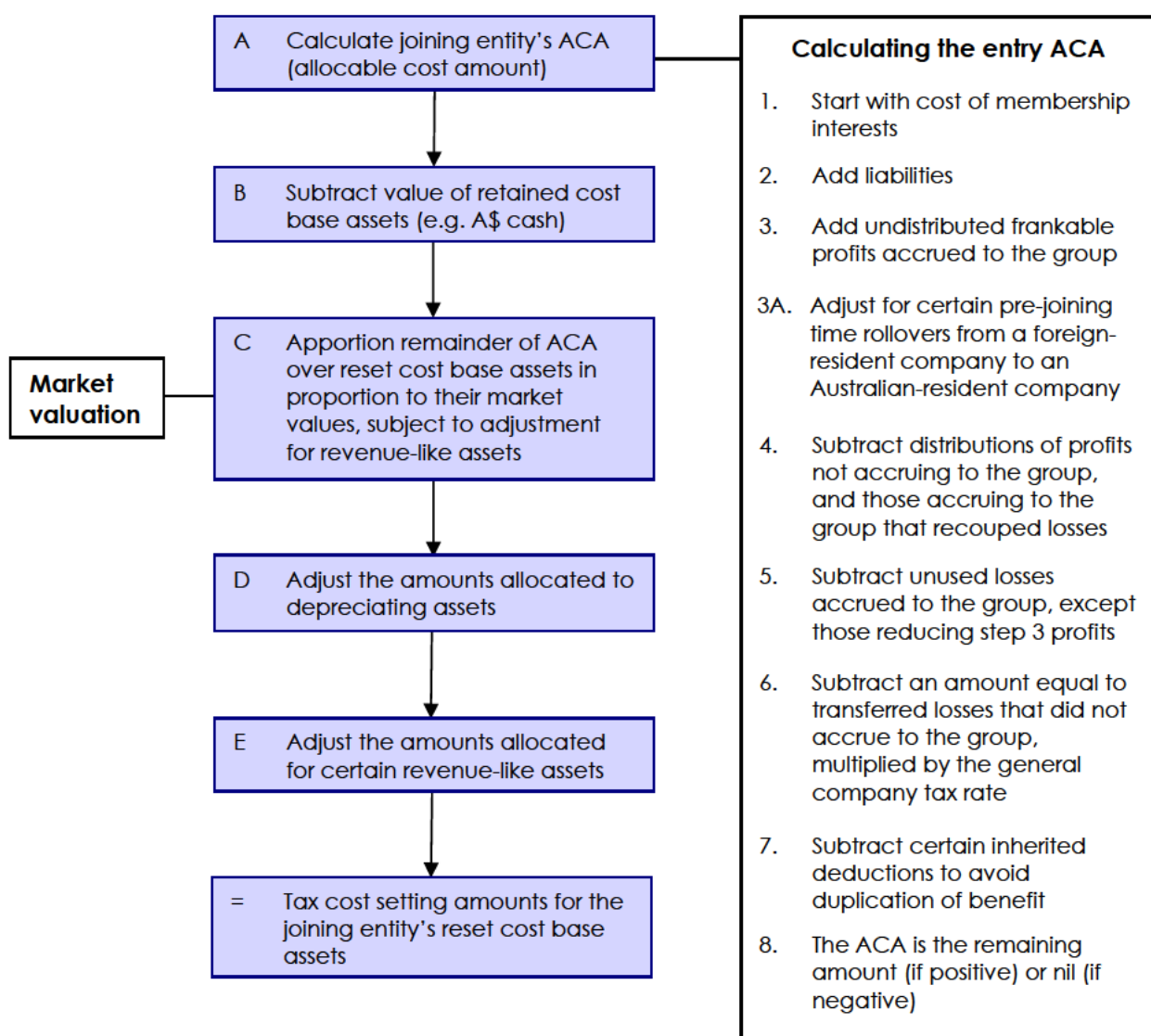

On formation or entry the tax cost of each asset of a joining subsidiary is based on a share of the allocable cost amount (ACA) of that subsidiary. The ACA consists of the cost of the membership interests in the entity together with its liabilities, which become liabilities of the group. Adjustments are made regards to reflect certain undistributed profits, distributions and losses of the joining entity and certain deductions to which the head company becomes entitled.

Part of the ACA is allocated to the subsidiary's *retained* cost base assets (i.e. assets such as cash that retain their cost bases at the joining time). The remainder of the ACA is then apportioned to the subsidiary's *reset* cost base assets in proportion to their market values, subject to further adjustments for assets held on revenue account and over-depreciated assets.

Assets not held by head company at joining time

Note that, at the joining time, tax costs are set for all assets that would be those of the joining subsidiary *if the single entity principle did not apply* → subsection 701-10(2), ITAA 1997; section 701-1, ITAA 1997; 'Single entity treatment', C9-1-110. This means that tax costs are reset even for those assets that are not recognised as being those of the head company under the single entity principle. Commonly, these would be intragroup assets, i.e. assets (such as a loan from the joining subsidiary to a group member) that correspond to a liability of another group member.

In working out any income tax consequences for the head company in relation to those assets, their reset tax costs are not taken into account, consistent with ignoring those assets under the single entity principle → section 701-58, ITAA 1997. However, setting their tax costs at the joining time absorbs some ACA that would otherwise be inappropriately allocated to the other reset cost base assets → paragraphs 2.54 – 2.60 of the Explanatory Memorandum to Tax Laws Amendment (2004 Measures No. 2) Bill 2004.

On formation

The cost setting process on formation is essentially the same as that for the entry of a single entity into a consolidated group, with some differences in the ACA calculation (step A in figure 1) and in the apportionment of the ACA over reset cost base assets (step C).

The formation cost setting rules are modifications of the basic case rules that apply when a single entity joins a consolidated group. Therefore, all the basic case rules in Subdivision 705-A of the *Income Tax Assessment Act 1997* (ITAA 1997) apply to the formation case, subject to the modifications contained in Subdivision 705-B. In addition, further modifications to both the basic and formation cases providing for transitional rules are included in Division 701 of the *Income Tax (Transitional Provisions) Act 1997* (IT(TP)A).

Loss integrity issues

Division 715 and Subdivision 719-T of the ITAA 1997 contain provisions that deal with loss integrity issues that may arise on formation and joining of consolidated or MEC groups.

→ 'Formation time treatment of assets owned by head company from a pre-consolidation changeover time', C2-6-510; 'Effect of Subdivision 165-CC for steps 1 and 2 of the ACA calculation at formation and joining times', C2-6-110; 'Effect of Subdivision 165-CD for MEC groups', C2-6-150

Head company's assets

On formation, the head company always retains existing tax values for its assets. When a consolidated group is formed, no changes are made in relation to the head company's assets, other than to the intragroup debt and intra-group membership interests it holds, which are not recognised for income tax purposes during consolidation.

Order of cost
setting
application

The cost setting process is applied separately to each subsidiary. When a group of entities linked by ownership forms or joins a consolidated group, the process is applied separately to each entity on a top-down basis → figure 2. (But this does not apply when a consolidated group joins another consolidated group → 'Modifications to entry cost setting rules', C2-1-040.)

When, for example, on formation a non-chosen subsidiary member (the first subsidiary) holds membership interests in another non-chosen subsidiary member (the second subsidiary), the membership interests in the second subsidiary are reflected as an asset in the first subsidiary's accounts. The cost setting rules must be first applied to the first subsidiary. The resulting cost setting amount for the membership interests in the second subsidiary is then used in working out the allocable cost amount for the assets in the second subsidiary. This rule only applies if all entities in the chain are non-chosen transitional entities.

In the following example (figure 2), the 1st cost setting application sets a new tax cost for A's shares in B. This new tax cost is then used in the ACA step 1 calculation for B (as part of the 2nd cost setting application) to set a new tax cost for B's shares in C. In turn this new tax cost is used in the ACA step 1 calculation for C (as part of the 3rd cost setting application) to set new tax costs for its assets.

Figure 2: Cost setting is applied top down on group formation

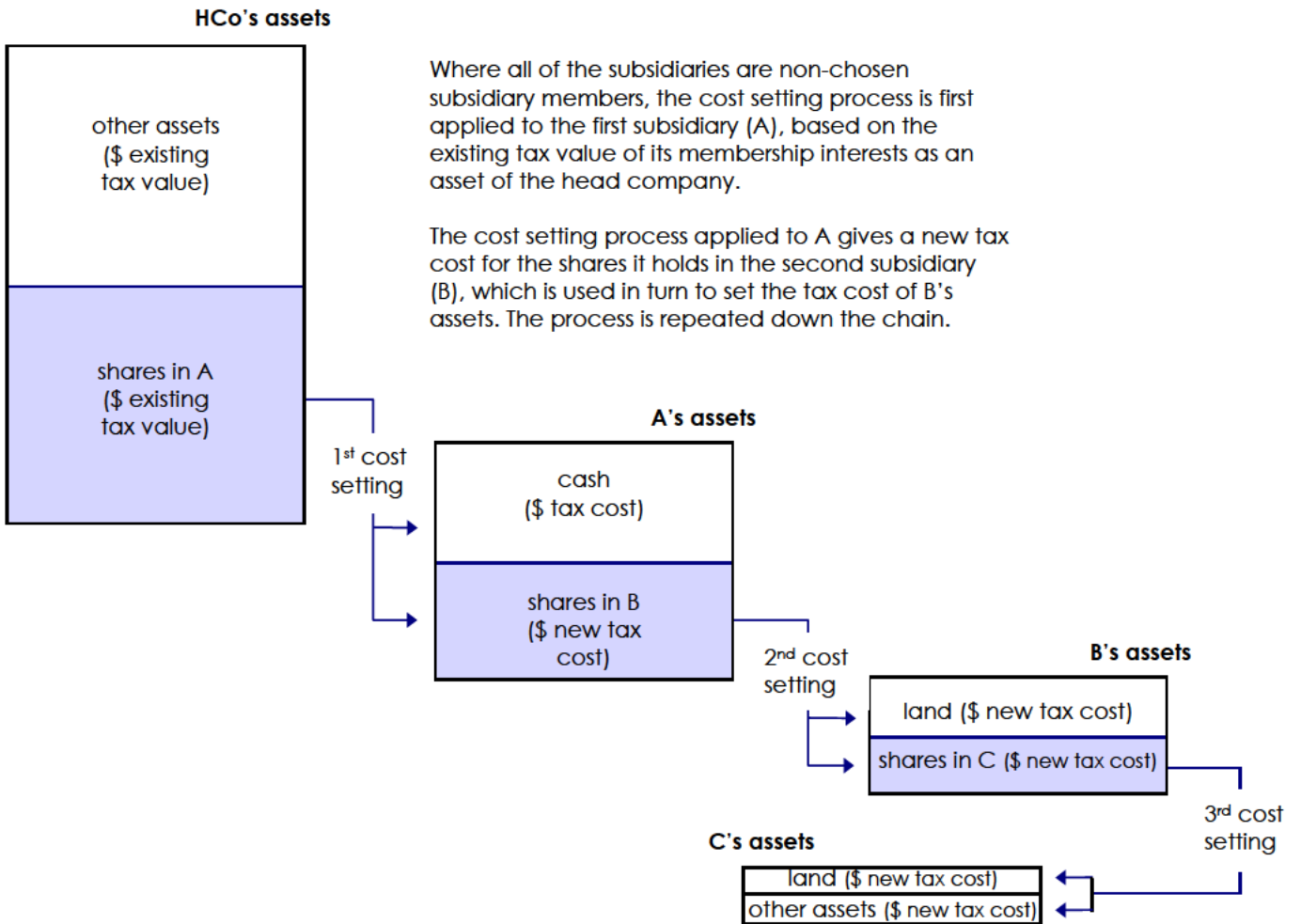

Note

Linked entities

The same top-down principle as applies to formation is followed when linked entities join a consolidated group. → 'Modifications to entry cost setting rules', C2-1-040. and section 705-225, ITAA 1997

Transitional rules

Transitional rules, including concessions intended to reduce compliance costs, apply to groups consolidating during the transitional period (1 July 2002 to 30 June 2004).

In particular, the head company may have the option of retaining the existing tax values for a subsidiary's assets (the 'stick' method) instead of applying the cost setting rules (the 'spread' method). This option is available on a subsidiary-by-subsidary basis, on the group's formation, provided the subsidiary is wholly owned on or before 30 June 2003 (and once wholly owned after 1 July 2002 it must remain so until the group consolidates). For example, a subsidiary that is a wholly-owned member of a consolidatable group on 1 July 2002, but which leaves the group three months later and then rejoins it on 30 June 2003 (after which the group consolidates) is not eligible for this option.

- A subsidiary that is eligible for the transitional option of retaining existing tax values is a 'transitional entity'.
- A group with at least one transitional entity is a 'transitional group'.
- A subsidiary for which the head company has chosen the transitional option is a 'chosen transitional entity' → 'Pre-formation changeover times – application of Subdivision 165-CC at formation (transitional period)', C2-6-520.

→ sections 701-1 to 701-5, IT(TP)A 1997

The head company can change its decision to stick or spread in relation to an entity provided it:

- makes the choice to use the stick method (assuming it had previously decided to spread) or revoke its original choice to stick (i.e. it has now decided to use the spread method) by 31 December 2005, and
- obtains agreement from any entity that has ceased to be a subsidiary and that held, at the leaving time, an asset previously held by the head company because of the single entity rule.

Where a head company has chosen to revoke a previous choice it should ensure that it keeps a written record of this decision. Where the revocation results in a change to the group's taxable income, the head company is required to lodge an amended income tax return as soon as practical after revoking the original choice.

→ subsections 701-5(4) and (5) IT(TP)A 1997

Note

- The value shifting and loss transfer provisions do not apply to membership interests in chosen transitional entities (that is, subsidiaries for which the head company has opted to retain existing tax values). → section 701-25, IT(TP)A 1997
- The formation rules outlined in this section are modified for a non-chosen subsidiary member in which some or all of the membership interests are held (directly or indirectly) by a chosen transitional entity. In this case, the chosen transitional entity is treated as a head company of a sub-group, and a notional ACA is calculated for the sub-group's interests in the non-chosen subsidiary (together with a corresponding amount for any interests held directly – or indirectly through non-chosen subsidiary members – by the consolidated group's head company). → section 701-20, IT(TP)A 1997

These amounts are calculated by including at ACA step 1 only the interests held by the sub-group (or head company) and then multiplying each of the ACA step 2 to 7 amounts by a fraction corresponding to the proportionate interest held by the sub-group (or head company) in the non-chosen subsidiary member. The result is the *sub-group's notional allocable cost amount*. Each sub-group's notional ACA (or, in the case of the head company, *the head company adjusted allocable amount*) are then aggregated to determine the actual ACA for the non-chosen subsidiary member.

→ worked example 'Calculating the ACA for non-chosen subsidiary partly held by chosen transitional entity', C2-4-205; section 701-20, IT(TP)A 1997; Taxation Determination TD 2004/73

Note

Pre-formation rollover after 16 May 2002 and transitional groups

If there has been a rollover of an asset under Subdivision 126-B or section 40-340 of the ITAA 1997, and:

- the rollover was after 16 May 2002
- the group consolidates after the rollover but before 1 July 2004
- because of the rollover, the tax values of the group's assets are different from what they would have been had the rollover not happened,

the rollover is disregarded for tax cost setting purposes on consolidation with certain exceptions. → sections 701-35 and 719-163, IT(TP)A 1997

The rule is intended to prevent groups from using rollover relief to maximise their choices for the cost setting of their assets on consolidation.

To enable a foreign-owned group that restructures to reset the cost of its assets on consolidation, an exception exists where the following conditions are satisfied:

- the rollover asset is a membership interest in an entity
- the membership interest is rolled-over from a foreign-resident company to an Australian-resident company
- the entity whose membership interests were rolled-over becomes a subsidiary member of a consolidated or MEC group at the time of formation
- the group is a transitional group, and
- the entity is not an eligible tier-1 company of a MEC group or a group member in which an interposed foreign-resident entity holds membership interests.

Concessions when a subsidiary leaves a transitional group

- When a subsidiary leaves a transitional group with an asset that was subject to an over-depreciated asset adjustment on entry, the head company may choose to add back the adjustment to the asset for the purpose of determining its cost base for membership interests. → section 701-40, IT(TP)A 1997
- When a subsidiary leaves a transitional group, its head company may choose to use formation time market values, instead of terminating values, for certain pre-CGT assets when reconstructing the cost bases of membership interests. The pre-CGT assets must be assets of the head company immediately before the formation time and not assets that were transferred to the head entity under a rollover. → section 701-45, IT(TP)A 1997

References

Legislation

Income Tax Assessment Act 1997, Subdivision 705-A; as amended by:

New Business Tax System (Consolidation) Act (No. 1) 2002 (No. 68 of 2002), Schedule 1

- *New Business Tax System (Consolidation, Value Shifting, Demergers and Other Measures) Act 2002* (No. 90 of 2002), Schedule 2
- *New Business Tax System (Consolidation and Other Measures) Act (No. 1) 2002* (No. 117 of 2002), Schedules 3 and 5
- *Taxation Laws Amendment Act (No. 6) 2003* (No. 67 of 2003), Schedule 3

Income Tax Assessment Act 1997, Subdivision 705-B; as amended by:

- *New Business Tax System (Consolidation, Value Shifting, Demergers and Other Measures) Act 2002* (No. 90 of 2002), Schedule 3
- *New Business Tax System (Consolidation and Other Measures) Act (No. 1) 2002* (No. 117 of 2002), Schedule 3

Income Tax (Transitional Provisions) Act 1997, Division 701; as amended by:

- *New Business Tax System (Consolidation, Value Shifting, Demergers and Other Measures) Act 2002* (No. 90 of 2002), Schedule 7
- *New Business Tax System (Consolidation and Other Measures) Act 2003* (No. 16 of 2003), Schedules 3
- *Taxation Laws Amendment (2005 Measures No 5) Act 2005*, (No 162 of 2005), Schedule 3

Income Tax (Transitional Provisions) Act 1997, subsections 701-5(4) and (5); as amended by the *Taxation Laws Amendment (2005 Measures No. 5) Act 2005* (162 of 2005), Schedule 3

Income Tax (Transitional Provisions) Act 1997, sections 701-35 and 719-163; as amended by:

- *New Business Tax System (Consolidation and Other Measures) Act 2003* (No. 16 of 2003), Schedule 17
- *Tax Laws Amendment (2006 Measures No 4) Act 2006* (No 168 of 2006), Schedule 2

Explanatory Memorandum to the New Business Tax System (Consolidation) Bill (No 1) 2002

Explanatory Memorandum to the New Business Tax System (Consolidation, Value Shifting, Demergers and Other Measures) Bill 2002

Explanatory Memorandum to the New Business Tax System (Consolidation and other Measures) (No 1) Bill 2002

Explanatory Memorandum to the Tax Laws Amendment Act (No 6) 2003, Paragraphs 3.4 and 3.9 to 3.48

Explanatory Memorandum to the Tax Laws Amendment (2005 Measures No 5) Bill 2005

Explanatory Memorandum to the New Business Tax System (Consolidation and other Measures) Bill (No 2) 2002

Explanatory Memorandum to the Tax Laws Amendment (2006 Measures No 4) Bill 2006

Tax determinations

TD 2004/73 – Income tax: consolidation: where the head company and a chosen transitional entity in a consolidated group hold separate membership interests in a non-chosen subsidiary, how does the group calculate the allocable cost amount for the non-chosen subsidiary?

TD 2005/24 – Income Tax: Consolidation: is an adjustment under section 705-160 of the *Income Tax assessment Act 1997* required where the relevant membership interests are in a chosen transitional entity with losses?

TD 2005/25 – Income tax: consolidation: if a transitional group has a non-chosen subsidiary in which all membership interests of the head company are held indirectly through a chosen transitional entity, and the non-chosen subsidiary has accrued profits, can an adjustment arise under section 705-160 of the *Income Tax Assessment Act 1997* when working out the head company adjusted allocable amount under section 701-20 of the *Income Tax (Transitional Provisions) Act 1997* for another non-chosen subsidiary?

Revision history

Section C2-1-010 first published as separate section 26 June 2007.

Proposed changes to consolidation

Proposed changes to consolidation announced by the Government are not incorporated into the *Consolidation reference manual* until they become law. In the interim, information about such changes can be viewed at:

- <http://assistant.treasurer.gov.au> (Assistant Treasurer's press releases)
- www.treasury.gov.au (Treasury papers on refinements to the consolidation regime).