

Worked example

## Consolidated and MEC groups – CGT rollover relief

**Description** This example explains the circumstances under which CGT rollover relief under Subdivision 126-B of the *Income Tax Assessment Act 1997* (ITAA 1997) is available for asset transfers within wholly-owned groups.

**Commentary** Broadly, CGT rollover relief for asset transfers within a wholly-owned group ceases on 30 June 2003 or when the group consolidates, whichever is earlier (in line with the end of the grouping provisions → 'Choosing', B1-1). However, after the introduction of consolidation, a limited form of CGT rollover relief is available for asset transfers within wholly-owned groups between:

- two non-resident companies, and
- a non-resident company and:
  - the head company of a consolidated group
  - the provisional head company of a multiple entry consolidated (MEC) group, or
  - a company that is not a member of a consolidatable group.

Note that the rollover could require an adjustment (step 3A) to an entity's allocable cost amount (ACA) → 'Pre-joining time rollover from foreign-resident company (ACA step 3A)', C2-4-270

→ Subdivision 126-B, ITAA 1997

CGT rollover relief remains available for a limited time beyond 1 July 2003 for asset transfers within wholly-owned groups headed by a company with a substituted accounting period (SAP) if certain conditions are satisfied. These conditions are explained later.

### **Example (a) Rollover between a non-resident and a head company of a consolidated group**

After consolidation, rollover relief will be available within a wholly-owned group for asset transfers between the head company of a consolidated group and a non-resident company.

An asset rolled over to a non-resident company (NR) by the head company (HC) of a consolidated group cannot be rolled over again to another Australian company by the non-resident company – it can only be rolled back to the same head company. (Note that due to the application of the single entity principle, the transfer of an asset involving a subsidiary member of a consolidated group is taken to be a transfer involving the head company of the group.)

In figure 1, HC2 transfers an asset to non-resident NR and they choose rollover relief. Subsequent rollover relief will be available should the non-

resident NR transfer the asset back to HC2, but relief will not be available for a transfer to HC1

**Figure 1**

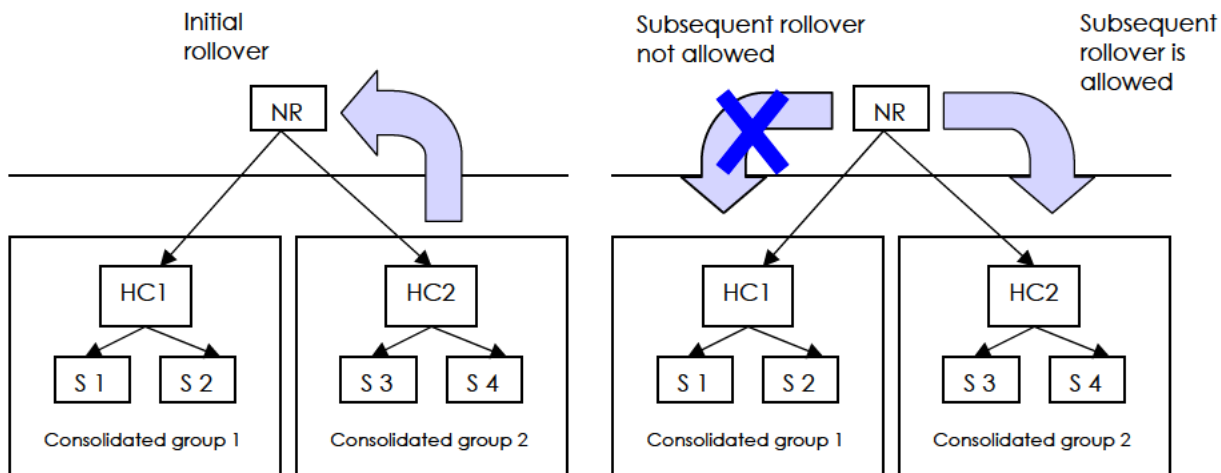

**(b) Rollover between a non-resident company and a head company of a MEC group**

This rule is relaxed for MEC groups to provide for possible changes in the provisional head company (PHC) of the group. If an asset is rolled over by the PHC of a MEC group to a non-resident company of the same wholly-owned group, that asset can subsequently be rolled back by the non-resident company to a different PHC of the same MEC group.

In figure 2, ACo, the PHC of the MEC group, rolls over an asset to non-resident NR. ACo, S1 and S2 leave the MEC group and BCo is appointed PHC. CCo, S5 and S6 then join the MEC group. NR can roll over the asset to BCo, which is the new PHC of the same MEC group.

**Figure 2**

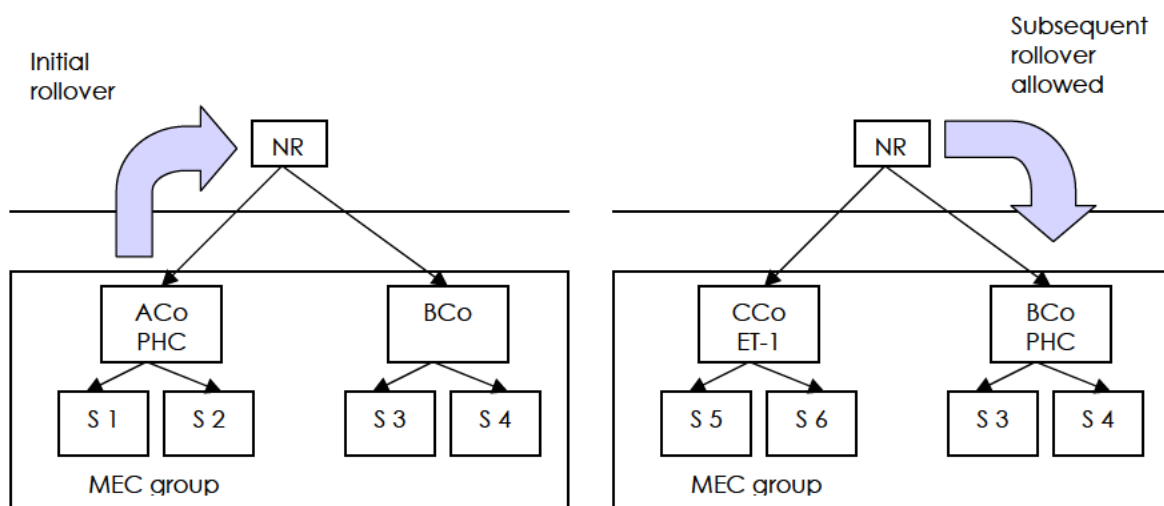

### (c) Groups with substituted accounting periods (SAPs)

CGT rollover relief in its current form will be extended beyond 1 July 2003 for a group with a head company (or provisional head company) that has a SAP only if the group consolidates on the first day of the head company's next income year after 30 June 2003. The extension will be from 1 July 2003 to the date of consolidation.

**Figure 3**

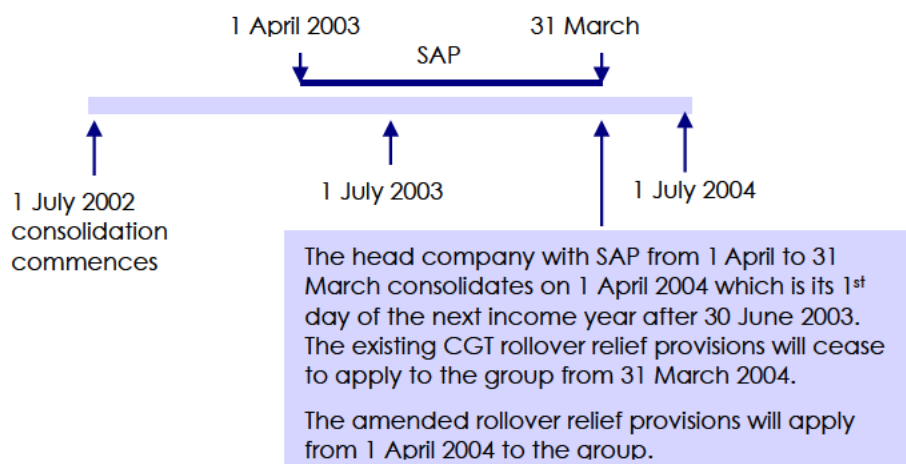

For rollover relief in its current form to apply, each of the following conditions must be satisfied:

- the company from which the asset was rolled over must become a member of the consolidated group on the day it forms
- the company should not have been a member of another consolidated or MEC group, and
- the group must consolidate on the first day of its head company's next income year after 30 June 2003 and before 1 July 2004.

For SAP groups that consolidate on any other date, rollover relief in its current form will cease to apply on 1 July 2003.

### Modifications to CGT event J1 – consolidated groups

Generally, CGT event J1 happens if there has been, under Subdivision 126-B, a rollover involving a CGT asset between two companies that are members of the same wholly-owned group, and the company that owns the CGT asset after the rollover stops being a wholly owned member of that group. The purpose of CGT event J1 is to reverse the benefit of the rollover.

An amendment to Subdivision 104-J of the ITAA 1997 ensures that CGT event J1 is not triggered if, after 30 June 2002, the company that owns the CGT asset after the rollover ceases to be a subsidiary member of a consolidated group (whether or not the company becomes a subsidiary member of another consolidated group at that time).

### Pre-formation rollover after 16 May 2002 and transitional groups

If there has been a rollover of an asset under Subdivision 126-B or section 40-340 of the ITAA 1997, and:

- the rollover was after 16 May 2002
- the group consolidates after the rollover but before 1 July 2004, and
- because of the rollover, the tax values of the assets of the group are different from what they would have been if the rollover had not happened,

the rollover is disregarded for tax cost setting purposes on consolidation, with certain exceptions. → sections 701-35 and 719-163, *Income Tax (Transitional Provisions) Act 1997*

The rule is intended to prevent groups from using rollover relief to maximise their choices for the cost setting of their assets on consolidation.

**Figure 4: Example: Subdivision 126-B asset rollover**

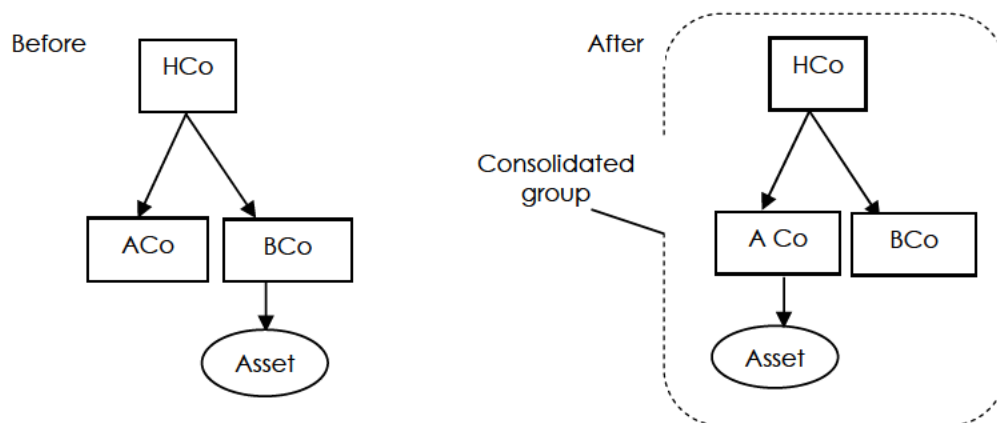

B Co rolls over an asset to A Co after 16 May 2002.

H Co, A Co and, B Co form a consolidated group before 1 July 2004.

If the tax values of the assets of the group are now different to what they would have been had the rollover not taken place, the cost of the assets are reset as if the rollover had not taken place.

To enable a foreign owned group that is restructuring to reset the cost of its assets on consolidation, an exception to the above rule exists where the following conditions are satisfied:

- the rollover asset is a membership interest in an entity
- the membership interest is rolled-over from a foreign-resident company to an Australian-resident company
- the entity whose membership interests were rolled-over becomes a subsidiary member of a consolidated or MEC group at the time of formation

- the group is a transitional group, and
- the entity is not an eligible tier-1 company of a MEC group or an entity in which a foreign-resident company or a non-resident trust holds membership interests.

**Figure 5a: Subdivision 126-B: Eligible tier-1 company rolled under**

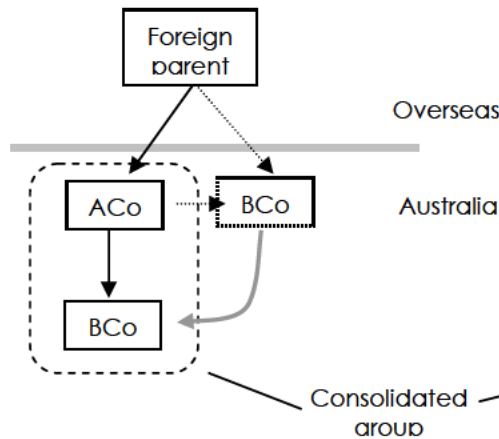

In figure 5a, the foreign parent rolls over its membership interests in BCo to ACo after 16 May 2002.

ACo and BCo form a consolidated group after the rollover but before 1 July 2004.

In this case, the rollover of the membership interests is *not* disregarded when the cost of the assets of the group are reset.

**Figure 5b: Subdivision 126-B: Foreign held subsidiary rolled under**

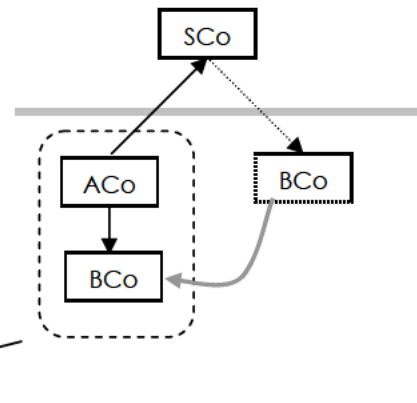

In figure 5b, SCo, a foreign subsidiary of ACo, rolls over its membership interests in BCo to ACo after 16 May 2002. ACo and BCo form a consolidated group after the rollover but before 1 July 2004.

In this case, the rollover of the membership interests is *not* disregarded when the cost of the assets of the group are reset.

---

## References

*Income Tax Assessment Act 1997*, sections 104-182 and 126-50; as amended by *New Business Tax System (Consolidation) Act (No. 1) 2002* (No. 68 of 2002), Schedule 3

Explanatory Memorandum to the New Business Tax System (Consolidation) Bill (No. 1) 2002, paragraphs 13.9 to 13.16 and 13.25 to 13.32

*Income Tax (Transitional Provisions) Act 1997*, section 701-35; as amended by *New Business Tax System (Consolidation, Value Shifting, Demergers and Other Measures) Act 2002* (No. 90 of 2002), Schedule 7

Explanatory Memorandum to New Business Tax System (Consolidated, Value shifting, Demergers and Other Measures) Bill 2002, paragraphs 1.104 to 1.107

*Income Tax (Transitional Provisions) Act 1997* sections 701-35 and 719-163 as amended by *New Business Tax System (Consolidation and Other Measures) Act 2003* (No 16 of 2003), Schedule 17

Explanatory Memorandum to New Business Tax System (Consolidation and Other Measures) Bill (No 2) 2002, paragraphs 5.75 to 5.88

*Income Tax Assessment Act 1997*, section 40-340