

## Capital benefit paid in substitution for dividends

**Description** This section shows how section 45B of the *Income Tax Assessment Act 1936* (ITAA 1936) applies where a member of a consolidated or multiple entry consolidated (MEC) group makes certain payments, allocations or distributions in substitution for dividends to recipients who are not members of the group.

**Commentary** The purpose of section 45B of the ITAA 1936 is to ensure that any part of certain payments, allocations and distributions made in substitution for a dividend is treated as a dividend for tax purposes.

Under subsection 45B(3), the Commissioner may make a determination with the effect that the whole or part of a 'capital benefit' becomes a dividend that is fully assessable, or subject to withholding tax, in the hands of the recipient → section 45C(1), ITAA 1936. Having made such a determination, the Commissioner may also make a further determination under subsection 45C(3) with the consequence that a class C franking debit may also arise in relation to the capital benefit.<sup>1</sup>

In a consolidated or MEC group it is possible in some circumstances for the head company and certain subsidiary members to make payments, allocations and distributions that are subject to section 45B. For example, membership interests in the following subsidiary members can be held directly by shareholders who are not members of the group → 'Eligibility tests and rules', C1-1:

- an eligible tier-1 (ET-1) company that is a member of a MEC group but is not its head company → section 719-15, *Income Tax Assessment Act 1997* (ITAA 1997),
- a company that is treated as a wholly-owned subsidiary due to employee shares being disregarded → section 703-35, ITAA 1997, or
- a company that is a transitional foreign-held subsidiary → section 703-45, ITAA 1997, and sections 701C-10 and 701C-15, *Income Tax (Transitional Provisions) Act 1997*.

The single entity rule (section 701-1, ITAA 1997) does not apply in determining, for the purposes of applying section 45B of the ITAA 1936, whether there is a scheme under which a person has been provided with a capital benefit by a company.

The reason for this is that the single entity rule applies only for the core purposes set out in section 701-1 – i.e. for working out the income tax liability or tax losses of the members of a consolidated group → 'Single entity treatment', C9-1-110. Where a member of a consolidated or MEC group provides a capital

<sup>1</sup> Subsection 45C(3) currently provides for a 'class C franking debit' to arise as a consequence of a determination made under that provision. However, under the Simplified Imputation System, which applies from 1 July 2002, debits arising in a franking account are now termed 'franking debits'. The Government has proposed amendments, with effect from 1 July 2002, which will include changing the reference made to class C franking debit in subsection 45C(3).

benefit to a person (the external shareholder), section 45B is relevant to working out the income tax liability or tax losses of the external shareholder but not that of the members of the group.

Accordingly, as the single entity rule has no application, the issue of whether an external shareholder has been provided with a capital benefit is determined on the basis that each member of a consolidated or MEC group retains its status as a separate entity.

Retaining this status as a separate identity may be relevant in considering threshold section 45B matters such as:

- whether there is a scheme under which a person is provided with a capital benefit by the subsidiary member → paragraph 45B(2)(a), ITAA 1997, and
- the ‘relevant circumstances’ of the scheme, having regard to various matters or amounts attributable to not only the subsidiary member that provided the benefit but also to associates of that company (within the meaning of section 318 of the ITAA 1936) → paragraph 45B(2)(c) and subsection 45B(8), ITAA 1997.

Associates of a consolidated or MEC group member include the other members of the group. As such, the relevant circumstances of the scheme under which a person is provided with a capital benefit include matters and amounts that relate to the other members of the consolidated or MEC group.

**Example** ACo and BCo are ET-1 companies of TopCo and are members of a MEC group for which ACo is the head company (Figure 1).

Foreign-resident company FCo 1 is interposed between TopCo and ACo. Foreign-resident company FCo 2 is interposed between TopCo and BCo.

Pursuant to a share capital reduction, BCo makes a payment to its shareholder FCo 2 such that FCo 2 is taken to have been provided with a capital benefit in terms of subsection 45B(5) of the ITAA 1936.

**Figure 1: Capital benefit paid outside MEC group**

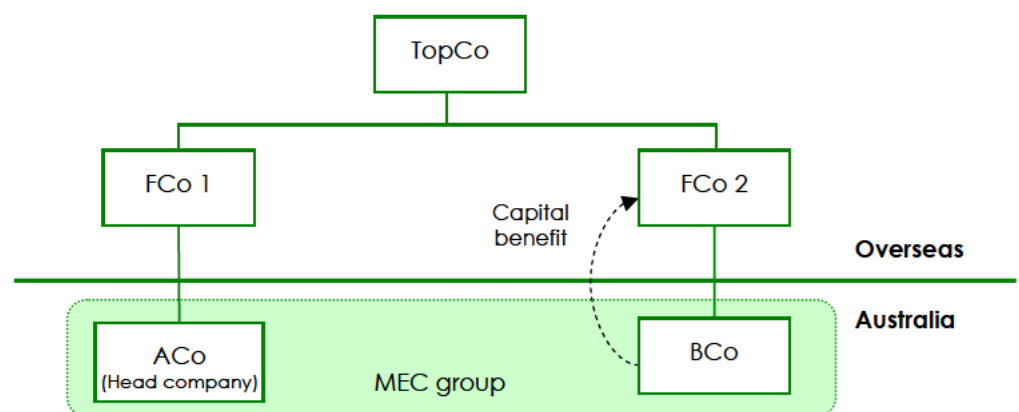

---

The single entity rule does not apply in determining whether section 45B applies to the capital benefit. This has been provided by BCo as a separate entity, and the application of section 45B must be determined on that basis.

The relevant circumstances of any scheme under which the capital benefit is provided by BCo to FCo 2 include any matters and amounts that relate to the associates of BCo, including ACo, the other member of the MEC group.

## References

*Income Tax Assessment Act 1936*, sections 45B, 45C and 318

*Income Tax Assessment Act 1997*, sections 701-1, 703-35, 703-45 and 719-15

*Income Tax (Transitional Provisions) Act 1997*, sections 701C-10 and 701C-15

Taxation Ruling 2003/8 – Income tax: distributions of property by companies to shareholders – amount to be included as an assessable dividend

Taxation Ruling 2004/11 – Income tax: consolidation: the meaning and the application of the single entity rule in Part 3-90 of the *Income Tax Assessment Act 1997*

PS LA 2005/21, Application of section 45B of the *Income Tax Assessment Act 1936* to demergers

### Revision history

Section C9-5-240 first published 12 September 2006.

### Proposed changes to consolidation

Proposed changes to consolidation announced by the Government are not incorporated into the *Consolidation reference manual* until they become law. In the interim, information about such changes can be viewed at:

- <http://assistant.treasurer.gov.au> (Assistant Treasurer's press releases)
- [www.treasury.gov.au](http://www.treasury.gov.au) (Treasury papers on refinements to the consolidation regime).