

Worked example

Identifying the test company to determine continuity of ownership of the focal company in a MEC group (COT transfer of losses)

Description This example shows how the test company is identified when a loss has been transferred to the head company of a MEC group in a series of continuity of ownership test (COT) transfers. → 'MEC groups and losses – determining whether the focal company satisfies the continuity of ownership test', C10-2-325 (high-level worked example)

Commentary In recognition of the special characteristics of MEC groups, Subdivision 719-F of the *Income Tax Assessment Act 1997* (ITAA 1997) modifies the rules about transferring and utilising losses within those groups.

The head company of a MEC group that is seeking to utilise a loss transferred to it from another company in the group is known as the focal company. It is considered to have satisfied the continuity of ownership test (COT) if the company defined as the test company satisfies that test. The tables in section 719-265 are used to identify the test company based on how the focal company made the loss.

When the COT transfer involves different companies, section 719-265 must be re-applied on the assumption that the transferor was the focal company (taking into account only things that happened before the transfer). The section is not re-applied if the COT transfer is from a company to itself as head company.

Example

Facts A tax loss made by SubCo in the year ended 30 June 2000 is transferred as a COT transfer under Subdivision 707-A to LCo, the head company of a consolidated group, on 1 July 2002.

On 1 July 2003, LCo becomes a wholly-owned subsidiary of ECo, an eligible tier-1 company of a MEC group. HCo, the head company of the MEC group notifies the Commissioner that LCo and SubCo have become members of the MEC group. The tax loss is transferred from LCo to HCo as a COT transfer.

HCo, the focal company, seeks to claim a deduction for the transferred tax loss in the year ended 30 June 2004. At all times since the MEC group formed, HCo has been the head company and TopCo has been the top company of the group.

Figure 1 shows the loss transfers within the group.

Figure 1: Loss transfers within the group

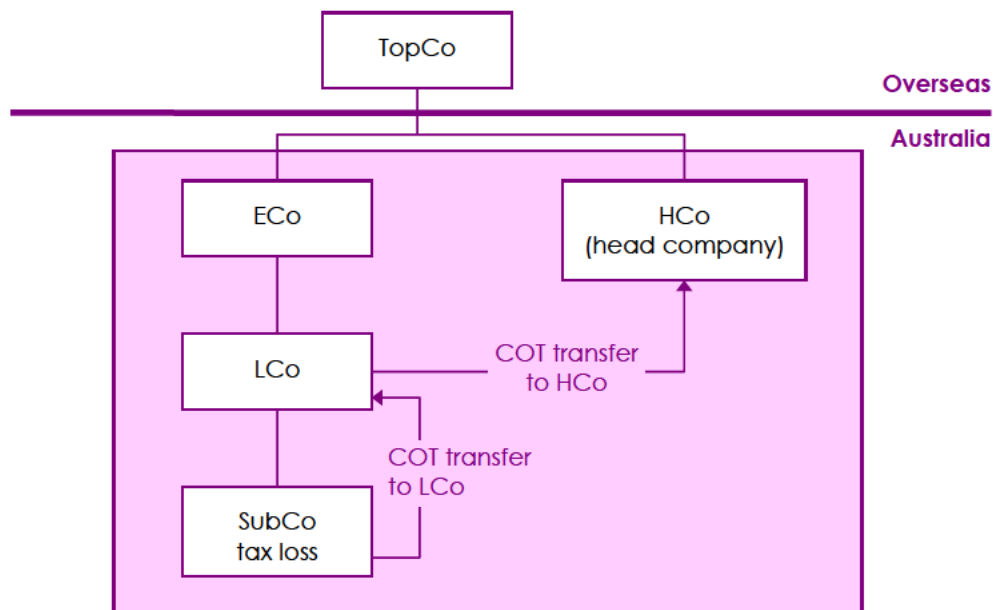

Calculation The test company is SubCo, as it is the first to transfer the tax loss.

First application of section 719-265 – focal company is HCo

The table in subsection 719-265(2) applies as the tax loss is considered to have been made by HCo, the focal company, because of a COT transfer.

Item 2 in the table applies as HCo, the focal company, and LCo, the transferor, are different companies.

Column 2 of item 2 in the table states that the test company is the company that is the test company for the transferor.

Re-application of section 719-265 – assumed focal company is LCo

In accordance with paragraph 719-265(1)(b), section 719-265 is re-applied assuming the focal company is the transferor, LCo.

In this re-application, the table in subsection 719-265(2) applies as the tax loss is considered to have been made by LCo, the assumed focal company, because of a COT transfer to LCo.

Item 2 in the table applies as LCo, the assumed focal company, and SubCo, the transferor, are different companies.

Column 2 of item 2 in the table states that the test company is the company that is the test company for the transferor.

Second re-application of section 719-265 – assumed focal company is SubCo

In accordance with paragraph 719-265(1)(b), section 719-265 is again re-applied assuming the focal company is the first transferor, SubCo.

In this re-application, the table in subsection 719-265(4) applies as the tax loss was not transferred under Subdivision 707-A from a company to SubCo, the assumed focal company.

Item 3 in the table applies as items 1 and 2 do not apply. SubCo is not the head company of a MEC group when it makes the loss (item 1) and the loss has not been transferred to SubCo from a trust (item 2).

Column 2 of item 3 in the table states that the test company is the focal company. The assumed focal company in this application of section 719-265 is SubCo. This means that SubCo is the test company for the actual focal company, HCo.

References

Income Tax Assessment Act 1997, section 165-12

Income Tax Assessment Act 1997, Subdivision 719-F, subsection 707-210(1A); as amended by *New Business Tax System (Consolidation and Other Measures) Act 2003* (No. 16 of 2003), Schedule 13

Explanatory Memorandum to the New Business Tax System (Consolidation and Other Measures) Bill (No. 2) 2002, Chapter 3